



# HF-Performer Intelligent for TL5 HE/HO lamps

## HF-Pi 1 14/21/24/39 TL5 EII 220-240V

HF-Performer Intelligent for Master and ECO TL5 HE/HO, TL-D and PL-L lamps HF-Performer Intelligent features automatic recognition of the connected lamp and is independently able to adjust its operation parameters exactly to the respective lamp. This results in a substantial benefit, especially for T5 lamps, as it means TL5 HE and HO lamps of the same length can be interchanged. With a choice of seven ballasts, the customer is able to handle efficiently every possible combination of Master TL5 and Eco, TL-D, and PL-L lamps. The ballast is primarily designed for Indoor application. For outdoor application, the luminaire should be minimum Class II need to be sufficiently protected against water & dust. The installation should also be guard against any lightning surge or any other necessary electrical protection as deemed in such typical installation & application.

### Product data

General Information		Mains Voltage Safety (AC)	
Application Code	EII		-10% - +10%
Type Version	mk1	Earth Leakage Current (Max)	0.5 mA
Lamp Type	TL5	Inrush Current Width	0.35 ms
Number of Lamps	1 piece/unit	Constant Wattage Deviation	-2% / +2%
Number of Products on MCB (16A Type B) (Nom)	18	Ballast Factor (Nom)	1.00
Automatic Restart	Yes	Power Losses (Nom)	1.9-2.5 W
		Inrush Current Peak (Max)	20 A
Operating and Electrical		Wiring	
Input Voltage	220 to 240 V	Connector Type Input Terminals	Insert
Input Frequency	50 to 60 Hz	Cable Capacity Output Wires Mutual (Nom)	70 pF
Ignition Method	Warm Start	Connector Type Output Terminals	Insert
Crestrfactor (Max)	1.7	Cable Length Hot Wiring	0.75 m
Ignition Time (Max)	5.0 s	Wire Striplength	8.0-9.0 mm
Mains Voltage Performance (AC)	-8% - +6%	Input Terminal Cross Section	0.50-1.00 mm <sup>2</sup>

## HF-Performer Intelligent for TL5 HE/HO lamps

Output Terminal Cross Section	0.50-1.00 mm <sup>2</sup>
Cable Capacity Output Wires to Earth (Nom)	70 pF

### System characteristics

Rated Ballast-Lamp Power	14-39 W
Power Loss on TL5 HO	2.2/2.4 W
Lamp Power on TL5 HO	24.3/37.5 W
System Power on TL5 HO	26.5/39.9 W
Rated Lamp Power on TL5 HO	24/39 W
Rated Lamp Power on TL5 HE	14/21 W
System Power on TL5 HE	16.6/23.6 W
Lamp Power on TL5 HE	14.7/21.2 W
Power Loss on TL5 HE	1.9/2.4 W

### Temperature

T-Ambient (Max)	50 °C
T-Ambient (Min)	-25 °C
T-Storage (Max)	80 °C
T-Storage (Min)	-40 °C
T-Case Lifetime (Nom)	75 °C
T-Case Maximum (Max)	75 °C
T-Ignition (Max)	50 °C
T-Ignition (Min)	-25 °C

### Mechanical and Housing

Housing	L360x30x22
---------	------------

### Emergency Operation

Battery Voltage Lamp Operation	198-276
--------------------------------	---------

### Approval and Application

Energy Efficiency Index	A2
-------------------------	----

IP Classification	IP 20 [ Ingress Protection 20]
EMI 9 kHz ... 30 MHz	EN55015
EMI 30 MHz ... 1000 MHz	EN 55022 Class B
Safety Standard	IEC 61347-2-3
Performance Standard	IEC 60929
Quality Standard	ISO 9000:2000
Environmental Standard	ISO 14001
Harmonic Current Emission Standard	IEC 61000-3-2
EMC Immunity Standard	IEC 61547
Vibration Standard	IEC68-2-6 F c
Bumps Standard	IEC 68-2-29 Eb
Humidity Standard	EN 61347-2-3 clause 11
Approval Marks	CE marking ENEC certificate VDE-EMV certificate
Temperature Marking	Yes
Emergency Standard	IEC 60598-2-22
Hum And Noise Level	Inaudible

### Product Data

Full product code	871150091494130
Order product name	HF-Pi 1 14/21/24/39 TL5 EII 220-240V
EAN/UPC - Product	8711500914941
Order code	913700624066
Numerator - Quantity Per Pack	1
Numerator - Packs per outer box	12
Material Nr. (12NC)	913700624066
Net Weight (Piece)	0.247 kg

## Dimensional drawing

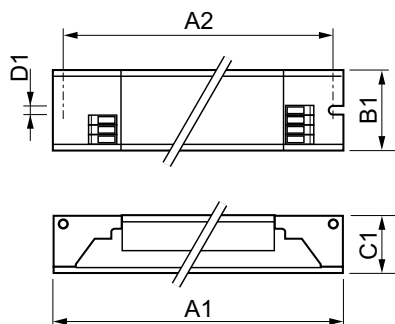

HF-Pi 1 14/21/24/39 TL5 EII 220-240V

Product	D1	C1	A1	A2	B1
HF-Pi 1 14/21/24/39 TL5 EII 220-240V	4.2 mm	22 mm	360 mm	350 mm	30 mm

## HF-Performer Intelligent for TL5 HE/HO lamps

